

SECTION A-A

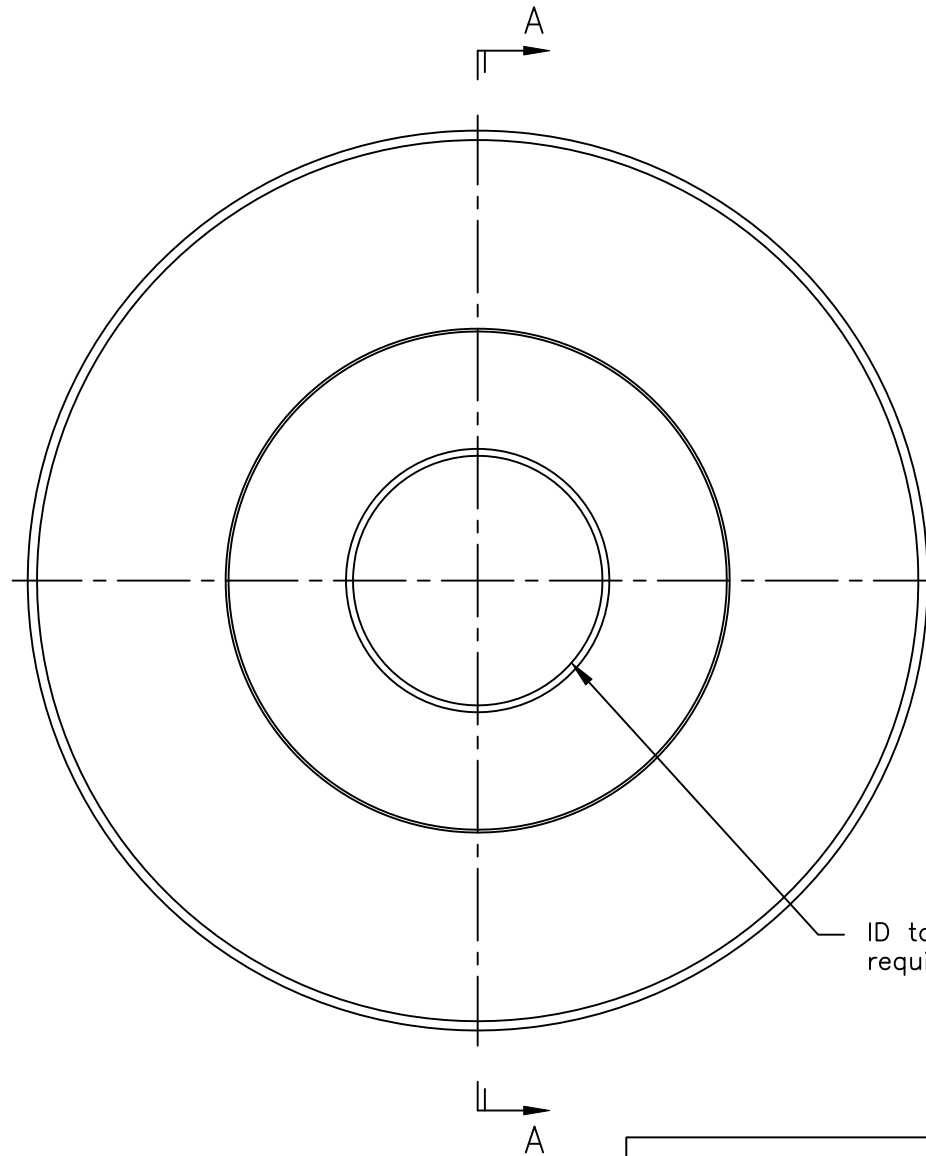

ID tolerance per customer requirements.

WEB PRINT

Circular knives are heat treated, to a hardness specified by customer requirements, up to 63 R/C.

Our circular knives are typically made from 52100 steel, but are also available in other tool steels such as D2 and M2. Other materials are also available for quote.

PORTAGE KNIFE COMPANY MANUFACTURER OF SCORE SLITTERS AND PERFORATORS
A DIVISION OF PORTAGE MACHINE CONCEPTS, INC. AKRON, OHIO (330) 784-0700

312-90-.093-FLAT

SIZE A	DWG NAME: W312-90-062-FLAT.dwg		
SCALE: NONE	DATE: 7/31/2019	DRAWN: D. MILLER	SHEET: 1 OF 1